

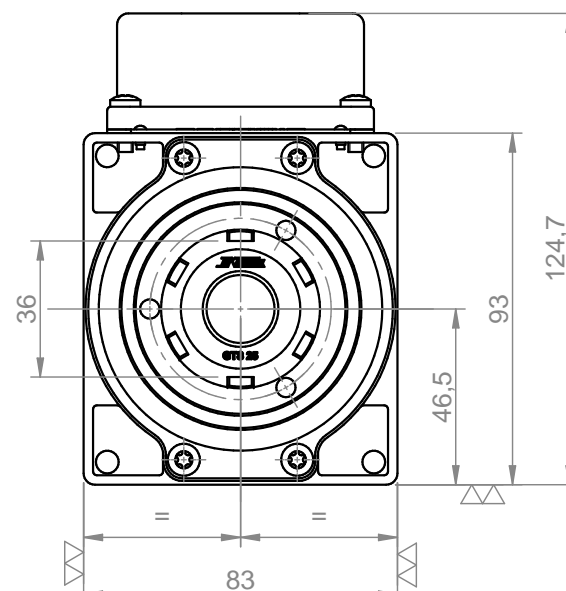

Ghiera serraggio  
GTS25 RH

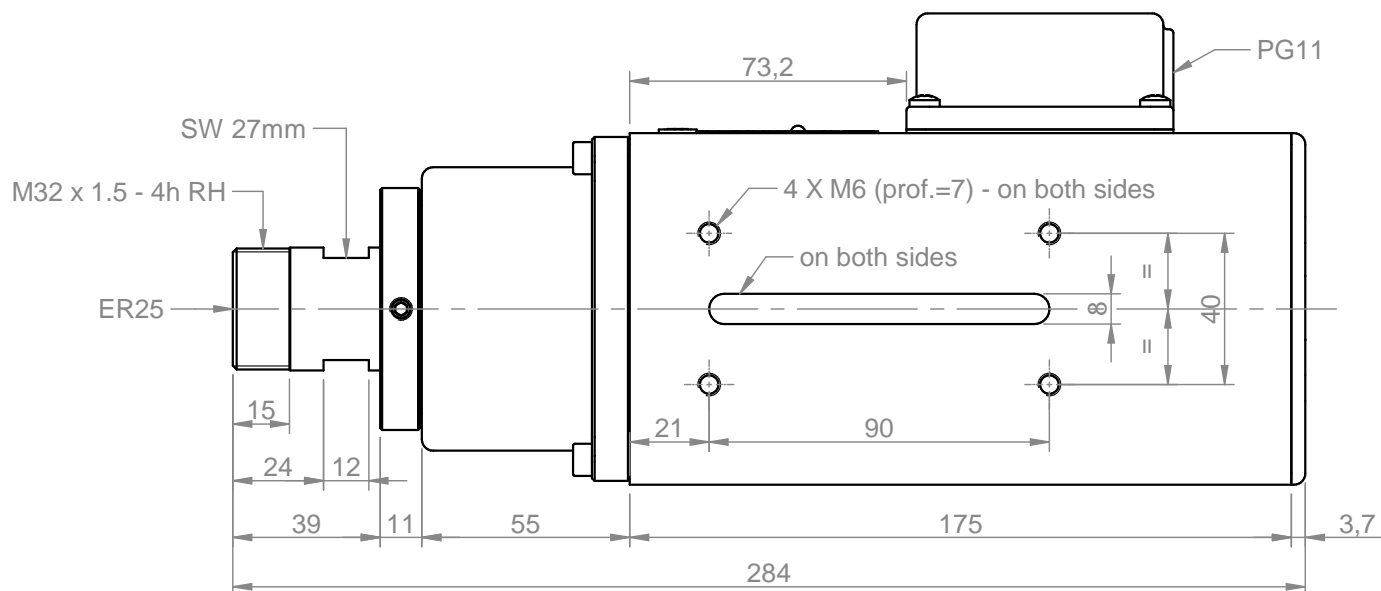
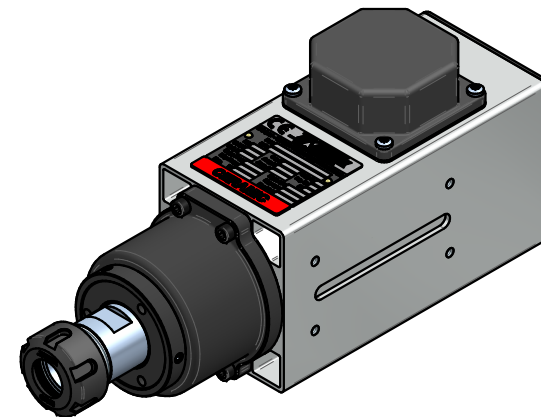
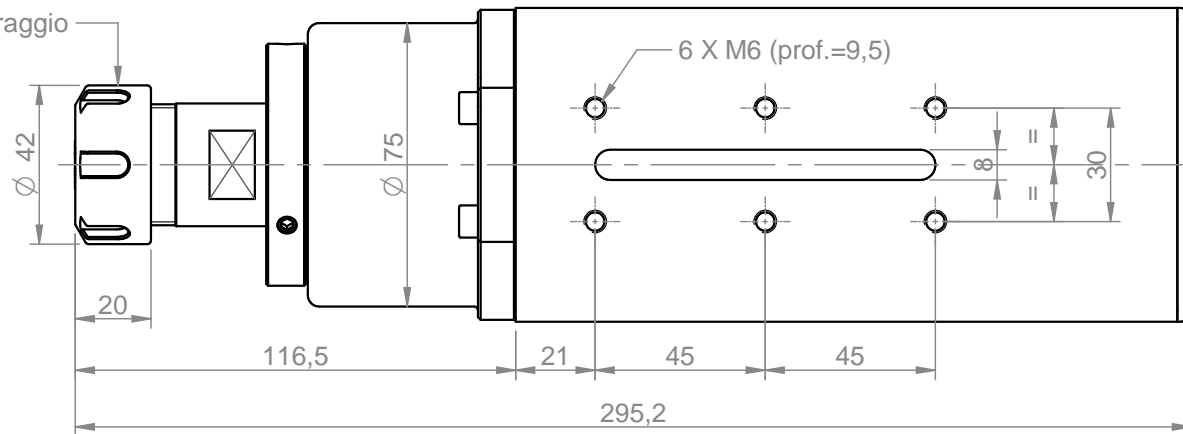

Power [kW]	Duty Cycle	Base speed [rpm]	Base freq. [Hz]	Base voltage Δ [V]	Absorb. Δ [A]	Base voltage Y [V]	Absorb. Y [A]	 <p>Teknomotor S.r.l. Via Argenega 31, I-32038 Quero Vas (BL) www.teknomotor.com</p>	
1.1	S1	18000	300	220	5.0	380	2.9		
Min speed [rpm]		Max speed [rpm]	Max freq. [Hz]	Protection	Ins. Cl.	Part number on nameplate		Title <b>4147-A-DB-P-ER25-HY-RH</b>	
6000		24000	400	IP54	F	COM41470347			
Balancing according to ISO 1940 - G2.5 @ 24000 rpm			Balancing type	cool type	full key	cool type	half key	Peso / weight	Customer <b>Catalogo</b>
							6.74 kg	Drawing code	
rev. n°	description			date		signature		Customer	
00	Emissione			18/05/2010		D. Bottarel		COM41470347	
								Tolleranze non quotate: UNI EN 22768 fH Smussi non quotati: 0.5 mm Rugosità secondo UNI ISO 1302	
drawn - date	approved - date	checked - date	sostituisce il		foglio / sheet		scala	A4	
D. Bottarel - 18/05/2010	S. Perli - 18/05/2010	S. Perli - 18/05/2010	sostituito dal		1 / 1		1:2		