

T-slot
UNI 5531
DIN 508

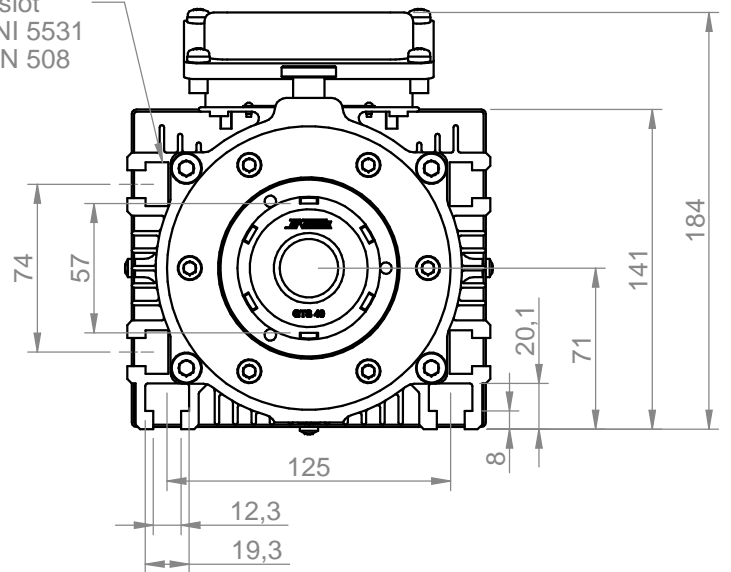

| | | | | | | | | | | | | | | | | | | | | | |
|---|-------------|-----------------|------|----------------------------|------|-----------------|------------|-----------------------|-----------------------|---|-----|-----------------------|------|----------------|---|----------------|--|-------|--|------------|--|
| Power [kW] | 4.0 | Duty Cycle | S1 | Base speed [rpm] | 3000 | Base freq. [Hz] | 50 | Base voltage Δ [V] | 220 | Base voltage Y [V] | 380 | Protection | IP54 | Ins. Cl. | F | | | | | | |
| Min speed [rpm] | 3000 | Max speed [rpm] | 6000 | Max freq. [Hz] | 100 | Absorb. Δ [A] | 15.2 | Absorb. Y [A] | 8.8 | Part number on nameplate COM71800354 | | | | | | | | | | | |
| Balancing: G2.5 - ISO 1940 @ maximum motor speed | | | | Balancing type Full Key | | | | tool type full key | tool type half key | Peso / weight 31.75 kg | | | | | | | | | | | |
| Tolleranze non quotate / unlisted tollerances: ±0.5mm Smussi non quotati / unlisted chamfers: ±0.5mm | | | | | | | ▽ = 0.8 | ▽ = 3.2 | ▽ = 12.5 | ~ = ∇ | | | | | | | | | | | |
| rev. n° | description | | | | | | date | signature | | Customer | | | | | | | | | | | |
| 00 | Emissione | | | | | | 20/01/2017 | D. Bottarel | | Catalogo | | | | | | | | | | | |
| drawn - date | | | | | | | | | | approved - date | | checked - date | | sostituisce il | | foglio / sheet | | scala | | Drawing n° | |
| E. Gaspari - 20/01/2017 | | | | | | | | | | S. Perli - 20/01/2017 | | S. Perli - 20/01/2017 | | sostituito dal | | 1 / 1 | | n.d. | | 5050 | |



Teknomotor S.r.l.
Via Argenege 31, I-32038 Quero Vas (BL)
www.teknomotor.com

Title
7180-C-2DB-P-ER40-RH

